

ID#: 287 Early evaluation results of charging programs and end-user behavior

Kevin Wood¹,

¹*Energetics, 2907 Shelter Island Drive, San Diego, CA 92106, KCWood@energetics.com*

Executive Summary

Insert summary text here in 10.5pt Times New Roman. The text of the executive summary outline is justified with 1.5 line spacing. The outline should contain between 50 and 150 words. The outline shall be enclosed within two horizontal lines 1pt thick.

Keywords: Please enter, in italics, five keywords from the provided list. The keywords on the paper shall match those selected when submitting.

1 Header

This is the template for the EVS36 symposium final paper. Your final paper, including the mandatory sections (header/title, summary, body/text and author(s)) should not exceed 12 pages.

The body of the text is Times New Roman 10.5pt, justified, with single line spacing.

Sections are numbered sequentially. Headings are 14pt bold; headings for Nomenclature, Acknowledgements, References and Authors are not numbered.

1.1 Subsections

Sub-headings should be numbered as above. Subsections are numbered sequentially. Headings are 12pt bold.

1.1.1 Sub-subsections

Sub-subheading, if any, are numbered as above. Sub-subsections are numbered sequentially. Headings are 10.5pt bold.

1.2 Header/Title Section

This denotes how to format the header of your paper. The title of the conference shall be set in 16pt Times New Roman italic. Title shall be set in 18pt Times New Roman bold. Author names in 12pt; affiliations (one affiliation per line, stating institution, address and email) in 9.5pt Times New Roman italic.

2 File requirements

The paper shall be uploaded as a pdf file only, made up to the specifications of this template. In the case special fonts (e.g. symbols) are used, these shall be embedded in the pdf file. The size of the file should not exceed 10MB for a total allowed length of a maximum of 12 pages.

3 Page and Column Dimensions

The printed page area and column dimensions are set as follows:

- Top and bottom margins 30 mm (1.18 inches)
- Left and right margin 25 mm (0.98 inches)

A footer is to be provided, with a horizontal line 1pt thick at 20 mm from the bottom of the page. Below the line, left align the statement "EVS36 International Electric Vehicle Symposium" and right align the page number, all set in 9.5pt Times New Roman.

4 Referencing

Referencing sources in the final paper shall be done with sequential numerical references, between square brackets. Examples of citing references are given in the references section, for books [1], journal articles [2] and websites [3]. Reference list is printed in 9.5pt text.

5 Figures, Tables and Equations

5.1 Figures

Captions for figures are 9.5pt, centered. Do not include separate lists of table and figure captions. Figures shall be sequentially numbered, lined up with the text, and referenced as Fig. 1.

Vector graphic files (.eps, .svg, .ai) are preferred for line drawings; bitmap figures like photos (.jpg) shall have sufficient resolution (300 ppi).

The use of colour figures is welcomed, but the choice of colours should allow a suitable contrast when reproduced on a monochrome printer.

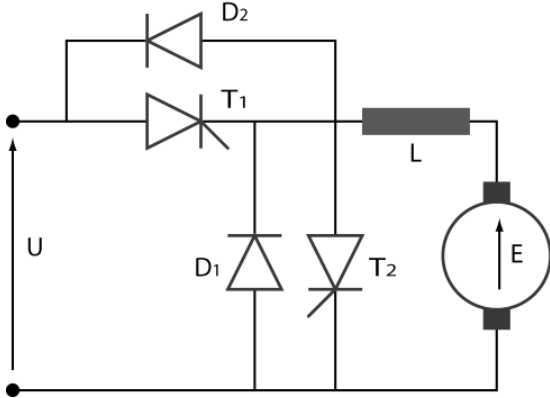

Figure1: Chopper for d.c. drive

5.2 Tables

Tables shall have their own sequential numbering independent from the figures numbering, and captions shall be placed above the table. Tables spreading over 2 columns should be placed at the top or bottom of the page.

Table 1: Power levels for charging (230V)

	Current (A)	Power (kW)
Standard	16	3.5
Semi-fast	32	7.0

5.3 Equations

Equations shall be set within the text and numbered sequentially with number enclosed in round brackets.

$$E = \int U I \cos j \ dt \quad (1)$$

Acknowledgments

List acknowledgments here if appropriate.

For bibliography, please format as follows.

References

- [1] J.J. Romm, *The hype about Hydrogen*, ISBN 1-55963-704-8, Washington, Island Press, 2005
- [2] P. Van den Bossche et al., *SUBAT, an assessment of sustainable battery technology*, Journal of Power Sources, ISSN 0378-7753, 162(2006), 913-919
- [3] *EVS30*, <http://www.EVS30.org>, accessed on 2016-11-06

Presenter Biography



Presenting author should provide a short biography. Biographies should have a typical length of 5 to 10 lines, in 9.5pt font, be limited to main educational background and description of current activities, and preferably be accompanied by a photograph sized 20mm x 30mm. The photograph shall be lined up with the bottom of the text paragraph.